



EIMCO ELECON

AL520 WHEEL LOADER

A step ahead in loading technology....



- Powerful Engine with 150 hp
- Bucket Capacity 1.9 - 3.0 Cum
- Payload 3500 kg.
- Hydrostatic Steering System
- Operating Weight 11010 kg.
- Bucket Self Leveling System

AL520

WHEEL LOADER

ENGINE

Make Cummins India Ltd.
Model B 5.9 - 150 C 31
Type TCIC Engine
Bore 102 mm
Stroke 120 mm
No. of Cylinder 6
Displacement 5.8 Ltrs.
Rated Power 150 hp @ 2200 rpm
Max Torque 650 Nm @ 1500 rpm

HYDRAULICS

Gear pump with two-way control valve with primary and secondary safeguard, servo-assisted joystick controls with float position for lifting cylinders.

Operating Pressure 210 bar
Flow@2200 rpm 160 l/min

ELECTRICAL

System Voltage 24 V
(2 x 12 V Batteries)
Charging Alternator 90 A

TRANSMISSION

ZF make Hydrodynamic Powershift 4 speed Automatic Transmission with Automatic as well as Manual Shifting Switches.

Gear Ratios :
Forward 4.012 - 2.024 - 1.088 - 0.619
Reverse 3.804 - 1.919 - 1.031

DRIVE

Epycyclic Hub Reduction Axles
Make & Model : Graziano PR 10 Front / PR 10 Rear
Overall Ratio 20.197:1
Gradability 60%
Oscillation $\pm 11^\circ$
Max. Speed kmph 40

TYRE

Standard 17.5 x 25 - 20 PR
(Heavy Duty)



BRAKES

Service Brake F/R Wet Disc Brake
Total Braking Area cm² 4713 x 2 per axle
Parking Brake SAHR Disc Brake,
Switch Operated

STEERING SYSTEM

Articulated frame. Hydrostatic power steering system provides smooth, responsive steering control at any speed

Max. Steering angle $\pm 38^\circ$
Turning Radius 5685 mm

SERVICE CAPACITIES

Hydraulic System 105 litres
Fuel Tank 172 litres
Engine Oil 15.4 litres
Transmission 30 litres
Rear Axle 29 litres
Front Axle 29 litres

CABIN

Comfortable & High visibility cabin fitted with door, side window & safety glasses all around.



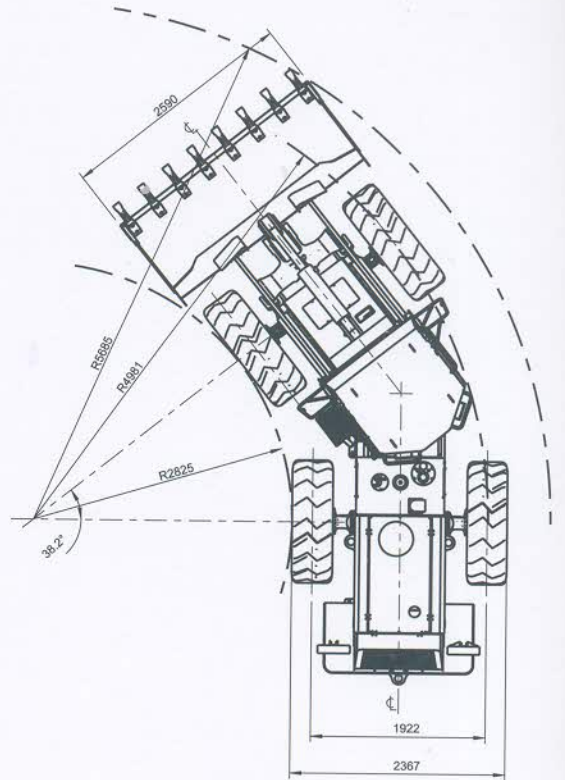
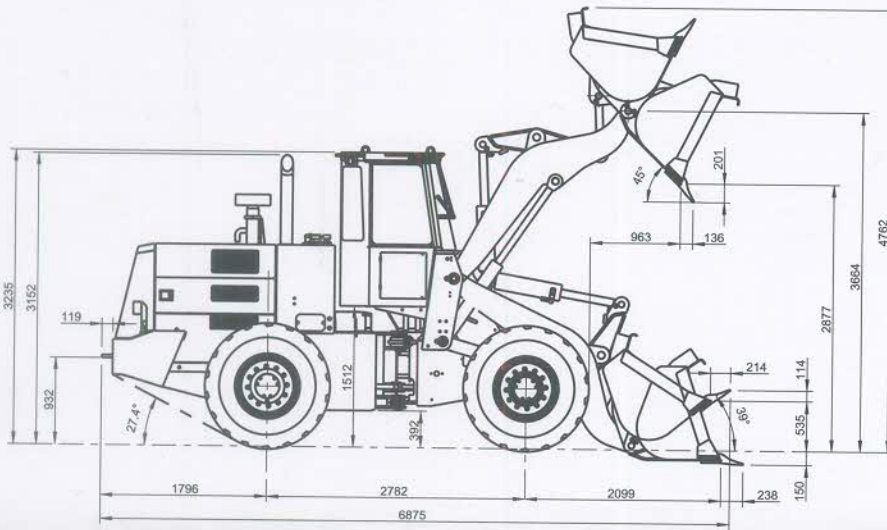

CYCLE TIME	
Raising Boom Time	5.9 sec
Lowering Boom Time	3.7 sec
Dumping Boom Time	1.5 sec

All dimensions shown above are for 1.9 CuM Standard Bucket, in mm, and may vary within +/- 5%
 Manufacturers reserve the right to amend/modify the specifications and/or design at any time without notice.



AUTHORIZED DEALER :



EIMCO ELECON (INDIA) LTD.

ANAND SOJITRA ROAD, VALLABH VIDYANAGAR 388 120, GUJARAT, INDIA.
 Tel. : (02692) 227859, 227883, 227850, Fax : (02692) 236506, E-mail : mktg.ces@eimcoelecon.in

BRANCH OFFICES

ASANSOL, BILASPUR, BANGALORE, CHENNAI, DHANBAD, JAMSHEDPUR, KOLKATA, MUMBAI, NEW DELHI & SECUNDERABAD

Aakash Printing & Stationery